

Some High-Speed Data Acquisition Systems do require storing the data in non-volatile memory. For those cases where the read/write data rate exceeds the capabilities of even the highest performance NVMe SSDs, MLE has developed an FPGA-based NVMe RAID solution:

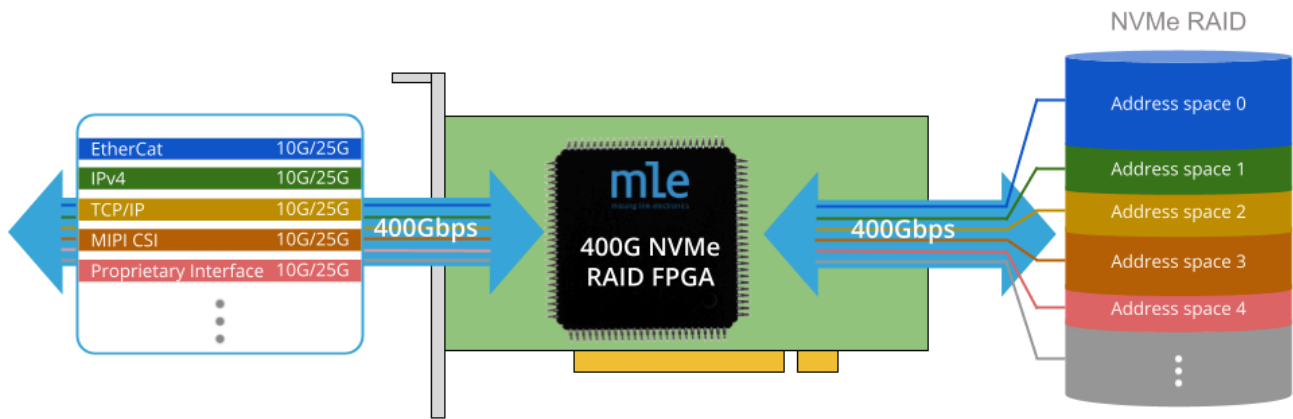

Now, you can transfer bulky data from multiple sensors to a RAID of NVMe SSDs at speeds up to 400 Gbps. MLE’s NVMe RAID implements a channel-based architecture, supports data-in-motion pre- and post-processing and is highly scalable with regards to bandwidth and recording capacity. Multiple systems can further be cascaded via high-accuracy IEEE time-synchronization for faster or deeper recording.

Adaptable signal front-ends support many different I/O standards in a “mix & match” fashion.

MLE’s NVMe RAID is compatible with Linux Software-RAID (via the Linux MD driver). This allows recording at high data rates and replaying at slower speeds, or vice versa.

Channel-Based Architecture

MLE’s NVMe RAID implements a channel-based architecture where each data source/sink can be associated with a dedicated RAID engine and a dedicated storage space. Each channel can have **10/25/50/75/100 Gbps**, or combinations thereof.

This channel-based architecture along with the combination of FPGA NVMe Recording Stack plus a well-tuned PCIe setup, delivers a best-in-class price/performance ratio for high-speed data acquisition, recording and replay. MLE’s multi-core NVMe Host Controller Subsystem supports dedicated NVMe queues per SSD in a PCIe Peer-to-Peer communication.

Applications

- Autonomous Vehicle Path Record & Replay
- Automotive / Medical / Industrial Test Equipment
- High-speed Radar / Lidar / Camera Data Acquisition & Storage
- Very Deep Network Packet Capture of Ethernet or IPv4 or TCP/UDP Data

Key Features

- Scalable from 100Gbps to 400Gbps
- Cascading of multiple systems with time-synch
- Start-Pause-Stop Data Recording
- Pre-trigger Data Recording in circular buffers
- Adaptable signal front-ends
- Read/write compatible with Linux Software-RAID

Scalability

MLE’s NVMe RAID supports a wide range of NVMe SSDs and can be scaled from M.2 SSDs for small and light-weight embedded systems up to large 19” racks using high-performance U.2 or U.3 SSDs. Scalability also includes selecting from different SSD capacities and Drive-Writes-per-Day (DWPD) models. Here a table of possible recording times in minutes:

| | | Recording Speed (Gbps) | | | | | | |
|---------------|----|------------------------|------|------|------|------|------|------|
| | | 100 | 150 | 200 | 250 | 300 | 350 | 400 |
| Storage (TiB) | 5 | 7.2 | 4.8 | 3.6 | 2.9 | 2.4 | 2.0 | 1.8 |
| | 10 | 14.3 | 9.5 | 7.2 | 5.7 | 4.8 | 4.1 | 3.6 |
| | 15 | 21.5 | 14.3 | 10.7 | 8.6 | 7.2 | 6.1 | 5.4 |
| | 20 | 28.6 | 19.1 | 14.3 | 11.5 | 9.5 | 8.2 | 7.2 |
| | 25 | 35.8 | 23.9 | 17.9 | 14.3 | 11.9 | 10.2 | 8.9 |
| | 30 | 42.9 | 28.6 | 21.5 | 17.2 | 14.3 | 12.3 | 10.7 |
| | 35 | 50.1 | 33.4 | 25.1 | 20.0 | 16.7 | 14.3 | 12.5 |
| | 40 | 57.3 | 38.2 | 28.6 | 22.9 | 19.1 | 16.4 | 14.3 |
| | 45 | 64.4 | 42.9 | 32.2 | 25.8 | 21.5 | 18.4 | 16.1 |
| | 50 | 71.6 | 47.7 | 35.8 | 28.6 | 23.9 | 20.5 | 17.9 |

Data Recording Use Cases

Besides record/replay of raw data we support data-in-motion pre- and post-processing that enables you to add your custom algorithms for indexing and metadata generation, on-the-fly data decimation, or running in “spy-mode” as a transparent data proxy.

Ingress data from the high-speed sensors are transferred and recorded at-speed and as-is onto the NVMe RAID.

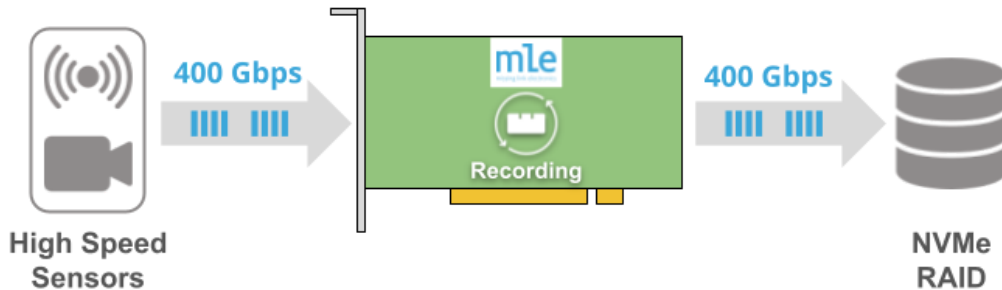

Communication from a high-speed data source can be transported to a data sink while this data is also recorded at-speed.

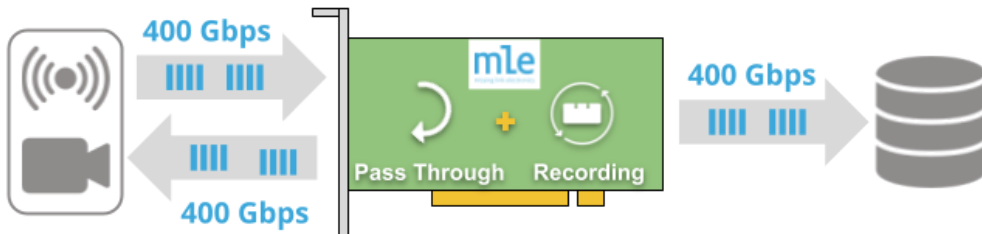

Unwanted pieces of the ingress data is removed on-the-fly prior to storage. This can, for example, be a selection of certain regions-of-interest (ROI).

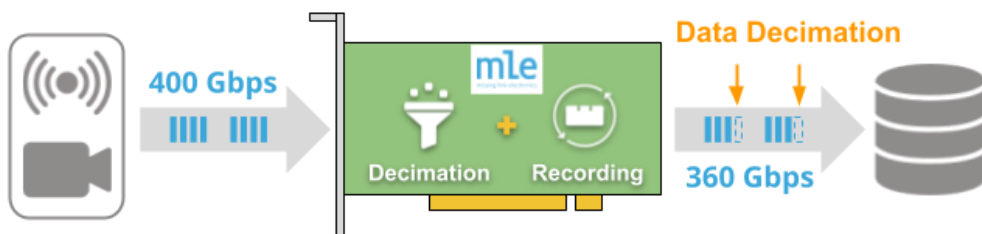

Ingress data can be analyzed on-the-fly to generate indexing information for later search, for example. This metadata is then recorded along with the ingress data. Metadata can, for example, be: Hardware timestamps, regions-of-interest, search indexes.



Availability Choices

- Turnkey System
- NVMe FPGA RAID Card based on off-the-shelf 3rd party FPGA cards
 - AMD Alveo U50 / U55C with Ultrascale+ and HBM
 - AMD Alveo V80 with Versal and HBM
 - Intel/Altera Agilex 7 AGF014 with DDR4
- FPGA Full System Stack (for select FPGA devices)

Contact Information

MLE USA: San Jose, CA
+1-408-475-1490

MLE Germany: Neu-Ulm
+49-731-141149-0

Email: sales-web@mlecorp.com

Missing Link Electronics (MLE)

We are a Silicon Valley based technology company with offices in Germany. We are partner to leading electronic device and solution providers and have been enabling key innovators in the automotive, defense, industrial, medical, test & measurement markets with FPGA-based subsystems and systems.

Our mission is to develop, support and market Domain-Specific Architectures for High-Performance Compute and Embedded Systems by accelerating and offloading open-source (Linux) software with FPGA.

Our expertise is “packets” which means Data-in-Motion systems with high-speed I/O connectivity and acceleration of data communication protocols as they are, for example, used in networking, storage and audio/video processing. We have been opening up FPGA technology for high-speed analog applications, and have been driving the integration and optimization of Open Source Linux and Android software stacks on modern heterogeneous processing architectures. This is complemented by expertise in Functional Safety and Security / Trusted Execution (OP-TEE).